

NOTE:
Please read all instructions
carefully before using this
product

Table of Contents

Safety Notice

Important Assembly
Information

Care and Maintenance

Parts List Warranty

Ordering Parts

Model
BE5000

Retain This
Manual for
Reference

06122016

**OWNER'S
MANUAL**

[Type text]



MARCY®

MARCY® ECLIPSE BE5000 OLYMPIC WIDTH BARBELL BENCH

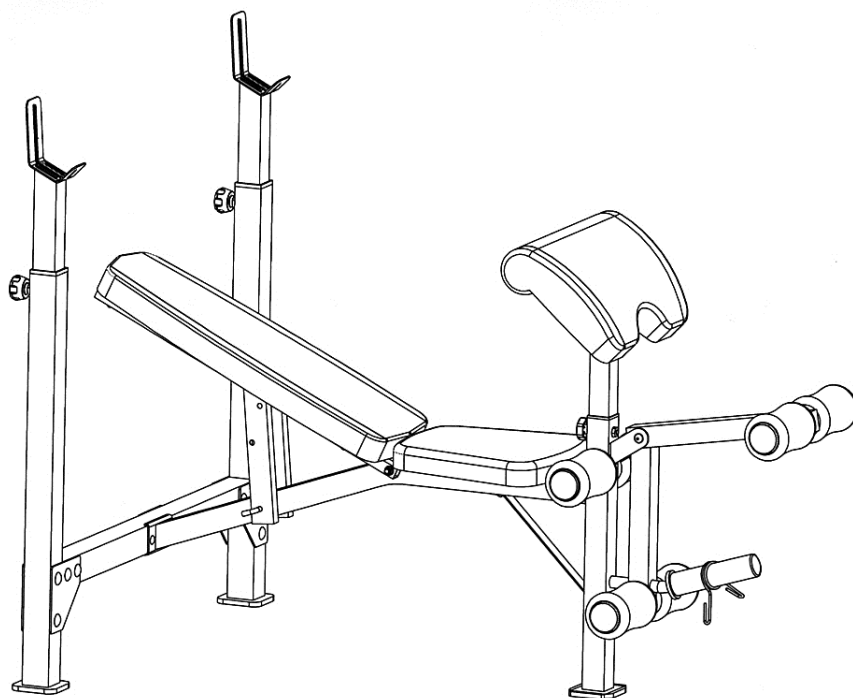

IMPORTANT: Please read this manual before commencing
assembly of this product.

TABLE OF CONTENTS

BEFORE YOU BEGIN.....	1
IMPORTANT SAFETY NOTICES.....	2
EXERCISE GUIDELINES.....	3
WARNING LABEL PLACEMENT.....	5
IMPORTANT ASSEMBLY INFORMATION.....	6
CARE AND MAINTANENCE, WEIGHT CAPACITY, OPERATING NOTES	7
PARTS LIST	8
EXPLODED DIAGRAM.....	9
WARRANTY.....	10
ORDERING PARTS.....	10

BEFORE YOU BEGIN

Thank you for selecting the MARCY Eclipse BE5000 Olympic Width Barbell Bench. For your safety and benefit, read this manual carefully before using the equipment. As the official distributor for Marcy, we are committed to providing complete customer satisfaction. If you have any questions, or find there are missing or damaged parts, we guarantee complete satisfaction through direct assistance. To avoid unnecessary delays, please contact our Customer Solutions Department, Monday to Friday 8am – 5pm GMT.

Pure-Tec Limited
www.puretecfitness.com
TEL: +44 (0) 1482 212098
Email: service@puretecfitness.com
Monday – Friday 0800 – 1700 GMT

IMPORTANT SAFETY NOTICE

This exercise equipment is built for optimum safety. However, certain precautions apply whenever you operate a piece of exercise equipment. Be sure to read the entire manual before you assemble or operate your equipment. In particular, note the following safety precautions:

1. **Keep children and pets away from the equipment at all times. DO NOT leave children unattended in the same room with the equipment.**
2. Only one person at a time should use the equipment.
3. If the user experiences dizziness, nausea, chest pain, or any other abnormal symptoms, STOP the workout at once. CONSULT A PHYSICIAN IMMEDIATELY.
4. Position the equipment on a clear, leveled surface. DO NOT use the equipment near water or outdoors.
5. Keep hands away from all moving parts.
6. Always wear appropriate workout clothing when exercising. DO NOT wear robes or other clothing that could become caught in the equipment. Running or aerobic shoes are also required when using the equipment.
7. Use the equipment only for its intended use as described in this manual. DO NOT use attachments not recommended by the manufacturer.
8. Do not place any sharp object around the equipment.
9. Disabled person should not use the equipment.
10. Before using the equipment to exercise, always do stretching exercises to properly warm up.
11. Never operate the equipment if the equipment is not functioning properly.
12. A spotter is recommended during exercise.
13. **This equipment is designed and intended for home and consumer use only, not for commercial use.**

WARNING: BEFORE BEGINNING ANY EXERCISE PROGRAM, CONSULT YOUR PHYSICIAN. THIS IS ESPECIALLY IMPORTANT FOR INDIVIDUALS OVER THE AGE OF 35 OR PERSONS WITH PRE-EXISTING HEALTH PROBLEMS. READ ALL INSTRUCTIONS BEFORE USING ANY FITNESS EQUIPMENT. PURE-TEC ASSUMES NO RESPONSIBILITY FOR PERSONAL INJURY OR PROPERTY DAMAGE SUSTAINED BY OR THROUGH THE USE OF THIS PRODUCT.

SAVE THESE INSTRUCTIONS.

EXERCISE GUIDELINES

Building Muscle and Gaining Weight

Unlike aerobic exercise, which emphasizes endurance training, anaerobic exercise focuses on strength training. A gradual weight gain can occur while building the size and strength of muscles. While developing muscle mass, your body adapts to the stress placed upon it. You can modify your diet to include foods such as meat, fish and vegetables. These foods help muscles recover and replenish important nutrients after a strenuous workout.

Muscle Strength and Endurance

To achieve the greatest benefit from exercise, it is important to develop an exercise program that allows you to work all of the major muscle groups equally.

To increase muscles strength; follow this principle:

Increasing resistance and maintaining the number of repetitions of an exercise results in increased muscle strength.

To tone your body, follow the principle: Decreasing resistance plus increasing the number of repetitions of an exercise results in increased body tone.

Once you feel comfortable with an exercise, you can change the resistance, the number of repetitions, or the speed at which you do the exercise. It is not necessary to change all three variables. For example, let's say that you are training at 22kgs and performing the exercise 10 times in 3 minutes. When this becomes too easy, you may decide to move up lifting 27kgs for the same number of repetitions in the same amount of time. Lifting more weights fewer times most often develops muscle strength. To gain both muscle strength and endurance, it is recommended that you perform each exercise 15 to 20 reps per set.

Training Intensity

How hard you begin to train depends on your overall level of fitness. The soreness you experienced can be lessened by decreasing the load you place on your muscles and by performing fewer sets. To avoid injury, you should gradually work into an exercise program and set the load to your individual fitness level. The load should increase as your fitness level increases.

Muscle soreness is common, especially when you first start exercising. If you are painfully sore for a long time, it may be time to change your program. Eventually, your muscle system will become accustomed to the stress and strain placed on it.

Beginning a Strength Building Program

Warming Up

To begin strength training, it is important to stretch and perform light exercise for 5 to 10 minutes. This helps prepare the body for more strenuous exercise by increasing circulation, raising your body temperature and developing more oxygen to your muscles.

Workout

Each workout to keep in mind that muscle soreness that lasts for a long period is not desirable and may mean that injury has occurred.

Cool Down

At the end of each workout, perform slow stretching exercises for 5 to 10 minutes. Ease into each stretch only going as far as you can. This stage allows your muscles wind down after training.

To provide a total workout program it is also recommended that 2 to 3 days of aerobic exercise is performed in addition to the strength training.

Drinking Water

For the body to function properly, it must be properly hydrated. If you are exercising, you should increase your fluid intake. The reason for this is that the water you take in will leave your system through the sweating mechanism that cools your body during exercise. The water you lose through exercise must be replaced so that the muscles can recover properly.

Rest Day

Although you may not feel like doing it, taking a rest day at least once a week is important because it gives your body a chance to heal itself. Continuously working your muscle will result in over training which will not benefit in the long run.

WARNING LABEL PLACEMENT

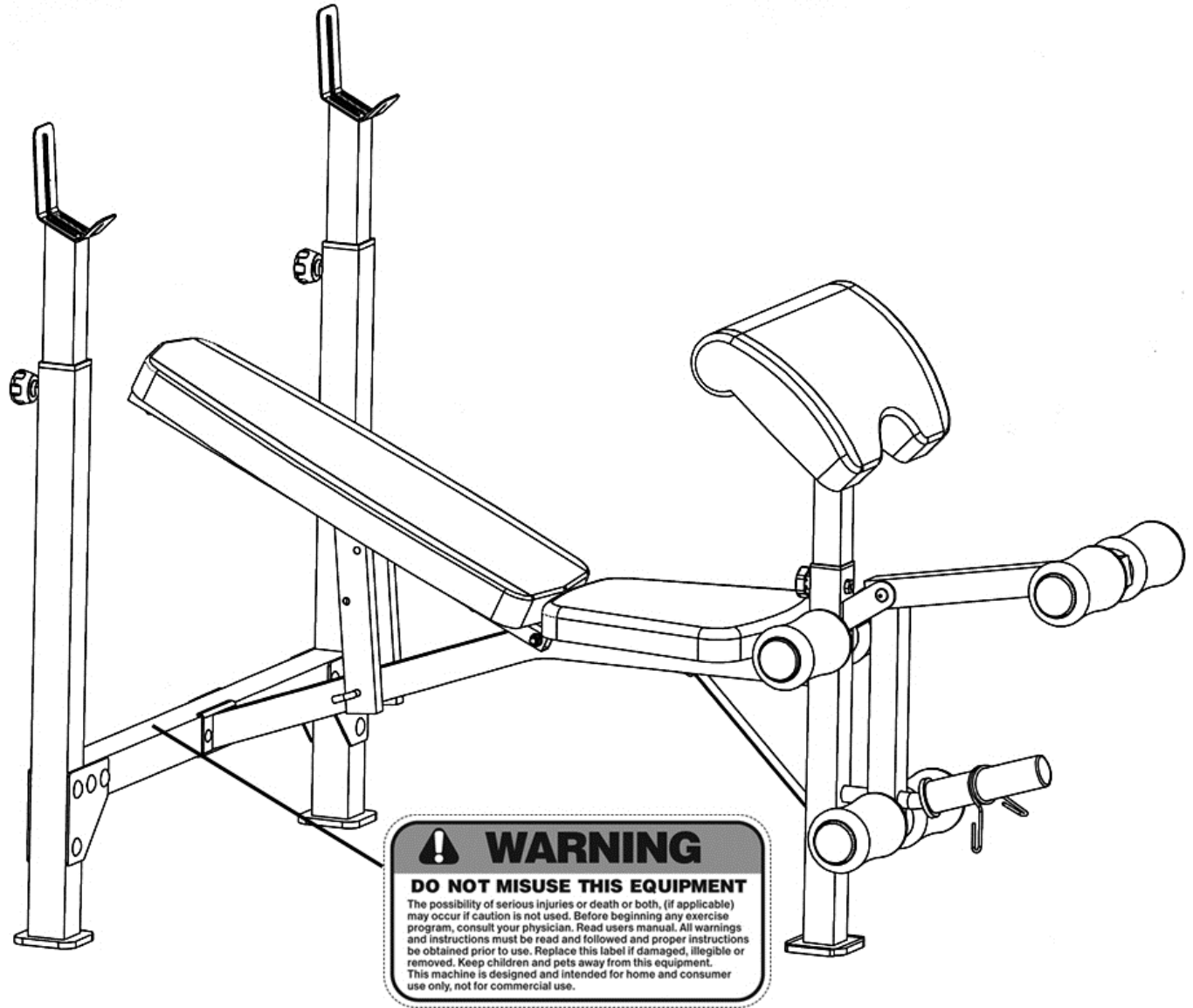

The warning labels shown here have been placed on the Cross Brace. If the labels are missing or illegible, please contact Customer Solutions by email: service@puretecfitness.com for replacements. Apply the labels in the location shown.

IMPORTANT ASSEMBLY INFORMATION

Tools Required for Assembling the Bench: Two Adjustable Wrenches and Allen Wrenches.

NOTE: It is strongly recommended that this equipment is assembled by two or more people to avoid possible injury.

Ensure **Carriage Bolts** are inserted through the **SQUARE holes** on components that need to be assembled. Attach washer only to end of the Carriage Bolt.

Use **Allen Bolts or Hex Bolts** inserted through the **ROUND hole** on components that need to be assembled.

Always wait until all bolts are assembled onto the bench before tightening the bolts. Do not tighten each bolt right after it is installed

Fasten Nuts and Bolts

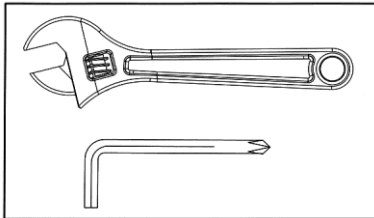

Securely tighten all Nuts and Bolts after all components have been assembled in current and previous steps.

NOTE: Do not over tighten any component with pivoting function.

Make sure all pivoting components are able to move freely.

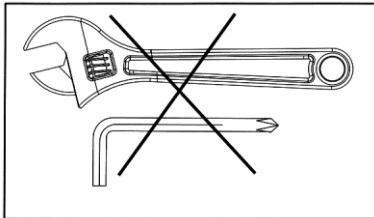

Do not tighten all Nuts and Bolts in this step.

CARE AND MAINTENANCE

1. Lubricate moving parts with WD-40 or light oil periodically.
2. Inspect and tighten all parts before using the equipment.
3. The equipment can be cleaned using a damp cloth and mild non-abrasive detergent. **DO NOT** use solvents.
4. Examine the equipment regularly for signs of damages or wear.
5. Replace any defective components immediately and/or keep the equipment out of use until repair.
6. **Failure to examine regularly may affect the safety level of the equipment.**

WEIGHT CAPACITY AND DIMENSION

1. Maximum weight on Crutches: 136kgs.
2. Maximum weight capacity (including user weight) on Bench: 272kgs.
3. Assembled Dimension: 168 x 115 x 143cms

OPERATING NOTES

1. Use the Lock Knob (#18) to select the Crutch height.
2. Use the L-shaped Lock Pin (#28) to select the Backrest Incline
3. Use the Lock Knob (#29) to select Arm Curl exercise height.

BACKREST ADJUSTMENT ANGLES

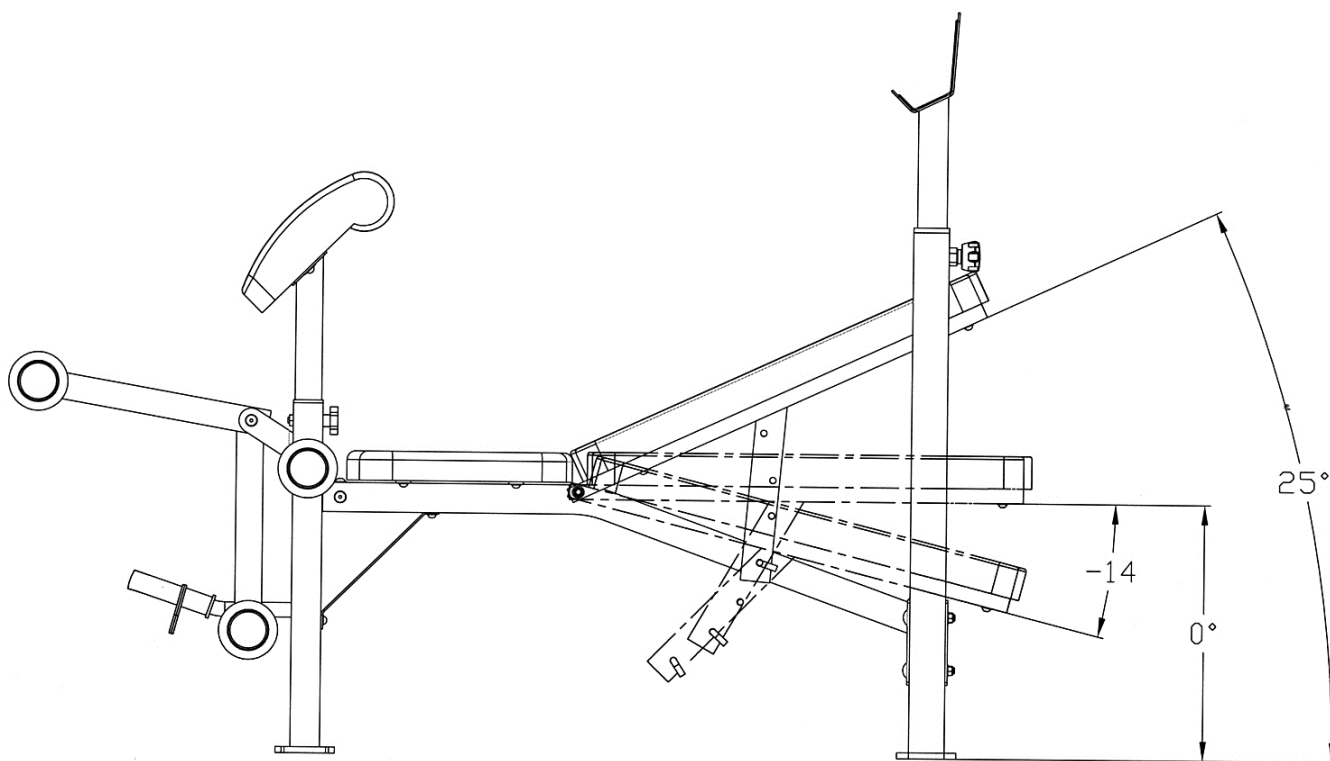

BE5000 PARTS LIST

PART NO.	DESCRIPTION	SIZE	QUANTITY
1	Upright		2
2	Crutch		2
3	Cross Brace		1
4	Main Seat Support		1
5	Front Post		1
6	Diagonal Support		1
7	Leg Developer		1
8	Upright Bracket		4
9	Left Backrest Support		1
10	Right Backrest Support		1
11	Foam Tube		3
12	Arm Curl Stand		1
13	Seat Pad		1
14	Backrest Board		1
15	Arm Curl Pad		1
16	Sleeve	1 3/8" x 2"	2
17	Sleeve	2" x 1 3/4"	1
18	Lock Knob	M18	2
19	End Cap	1" x 1"	2
20	End Cap	1" x 2"	2
21	End Cap	1 3/4" x 1 3/4"	3
22	End Cap	Ø 1"	1
23	Bushing	Ø 3/4" x Ø 5/8"	2
24	Foam Roll End Cap		6
25	Olympic Sleeve		1
26	Spring Clip	Ø 2"	1
27	Foam Roll		6
28	L-shaped Lock Pin		1
29	Lock Knob	M10 x 2 1/2"	1
30	Allen Bolt	M10 x 6 1/2"	1
31	Allen Bolt	M8 x 3/4"	8
32	Allen Bolt	M8 x 1 5/8"	4
33	Allen Bolt	M10 x 2 3/4"	1
34	Allen Bolt	M10 x 3/4"	3
35	Carriage Bolt	M10 x 3 1/8"	10
36	Washer	Ø 3/4"	17
37	Washer	Ø 5/8"	12
38	Aircraft Nut	M10	12
39	Bracket	2" x 4 3/4"	1
	Allen Wrench (Tool)	4#	1
	Allen Wrench (Tool)	5#	1
	Allen Wrench (Tool)	6#	1

EXPLODED DIAGRAM

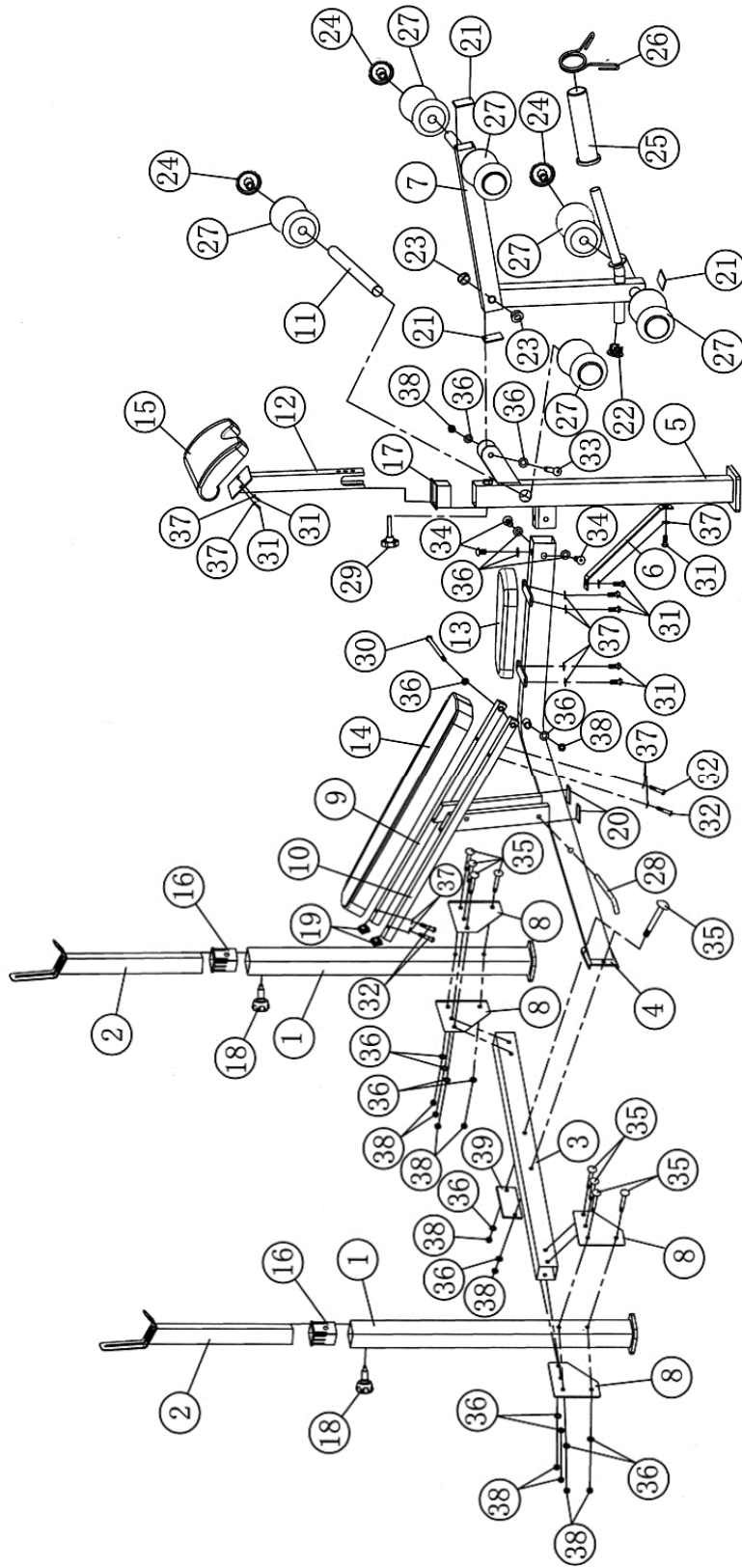

LIMITED WARRANTY

Pure-Tec warrants this product to be free from defects in workmanship and material, under normal use and service conditions. Please refer to www.puretecfitness.com for warranty terms. This warranty extends only to the original purchaser and is **valid for home use only**. Pure-Tec's obligation under this Warranty is limited to replacing damaged or faulty parts at Pure-Tec's option.

All returns must be pre-authorized by Pure-Tec. **This warranty does not extend to any product or damage to a product caused by or attributable to freight damage, abuse, misuse, improper or abnormal usage, purchasers own repairs or for products used for commercial or rental purposes.** No other warranty beyond that specifically set forth above is authorized by Pure-Tec.

Pure-Tec is not responsible or liable for indirect, special or consequential damages arising out of or in connection with the use or performance of the product or other damages with respect to any economic loss, loss of property, loss of revenues or profits, loss of enjoyments or use, costs of removal, installation or other consequential damages or whatsoever natures.

The warranty extended hereunder is in lieu of any and all other warranties and any implied warranties of merchantability or fitness for a particular purpose is limited in its scope and duration to the terms set forth herein.

Your statutory rights are not affected.

ORDERING REPLACEMENT PARTS

Replacement parts can be ordered by contacting our Customer Solutions Department,

www.puretecfitness.com

service@puretecfitness.com

When ordering replacement parts, please give the following information,

- 1. Model**
- 2. Description of Parts**
- 3. Part Number**
- 4. Date of Purchase**